

Thank you for purchasing a MiniTrac™ foam marking system. By following this installation, use and maintenance guide carefully, your unit will provide years of reliable service.

Richway Industries Ltd. makes a continued effort to improve its products. As such, we reserve the right to make design changes without obligations to add them to machines already in the field.

Please take a moment to fill out the following for future reference:

**Model #:** \_\_\_\_\_

**Serial #:** \_\_\_\_\_

**Date of Purchase:** \_\_\_\_\_

**Purchased From:** \_\_\_\_\_

## Table of Contents

<b>Safety First</b>	<b>Page 3</b>
<b>Installation</b>	<b>Page 5</b>
Tank & Power Unit Assembly	5
Foamheads	6
Foamhead Tubing	6
Switch Plate	8
Wiring	8
<b>Operation</b>	<b>Page 11</b>
Compressor Check	11
Mixing Foam	11
Filling the Tank	12
Flow Control Valve / Tubing Connections	13
<b>Maintenance</b>	<b>Page 16</b>
Foamheads & Screen-Strainer	16
Tank and Hoses	16
Winterization	16
<b>Trouble Shooting</b>	<b>Page 17</b>
<b>Appendices</b>	<b>Page 18</b>
Internal Components	18
Tank Components	20
Wire Diagram	20
<b>Warranty</b>	<b>Page 22</b>
<b>Company Information</b>	<b>Page 22</b>

## **SAFETY FIRST**



### **Important**

**Do not operate without reading and understanding this owners manual**



#### **Caution: To reduce the risk of explosion or fire**

- This foam marker is designed to operate off of a 12 volt DC power supply only.
- Do not attempt to operate machine without covers in place.
- Never operate this machine with a damaged electrical cord. Disconnect from electrical supply if machine is not working properly or cord is damaged.
- Disassembly or attempted repairs, if accomplished incorrectly can create electrical shock and/or short hazards. Only qualified personnel should perform repair service.
- Do not remove covers or attempt repairs while connected to electrical source.
- Never attempt to replace electrical wires and cables with smaller gauge or inferior wire and cable.
- Do not attempt to operate this machine without the appropriate fuse in place.
- Do not attempt to bypass fuse. If fuse is no longer serviceable, a real shock or short hazard may exist.
- Never replace original fuse with a higher amperage fuse.
- Inspect all components for damage after any electrical problem.
- Never operate this product in or near explosive atmospheres or where aerosol (spray) products are being used.
- Do not use air compressor to pump anything other than atmospheric air.
- Do not pump combustible liquids or vapors with this product or use in or near an area where flammable, explosive liquids, or vapors may exist.
- Do not use this product near flames.



### **Caution: To prevent injury**

- Never operate machine while unattended.
- Inspect machine for damage after use.
- Close supervision is necessary when this product is used near children or invalids.
- Never allow children to operate this machine.
- All electrical components generate heat. To avoid serious burns never touch internal components immediately after use.
- The air compressor in this unit may be thermally protected and may automatically restart when the protector resets. Always disconnect power source before servicing.
- Wear safety goggles and all proper clothing when operating, servicing or refilling this machine. Always read and follow manufacturer recommendations when handling any chemicals.
- Richway foam markers are designed to operate at low pressure. Personal injury may result when air pressure exceeds 15 psi.
- Do not attempt, for any reason, to remove tank cap while machine is turned on.
- Chemical mist or liquid can cause permanent eye, skin or lung damage or death. Always wear proper protective clothing, goggles, aspirator, gloves or other protective garments as recommended by the labels of the chemicals used.

## INSTALLATION

To install MiniTrac foam markers, several components must be connected. Every application may be slightly different. The following is a guide to help you choose the best locations for installing its components.

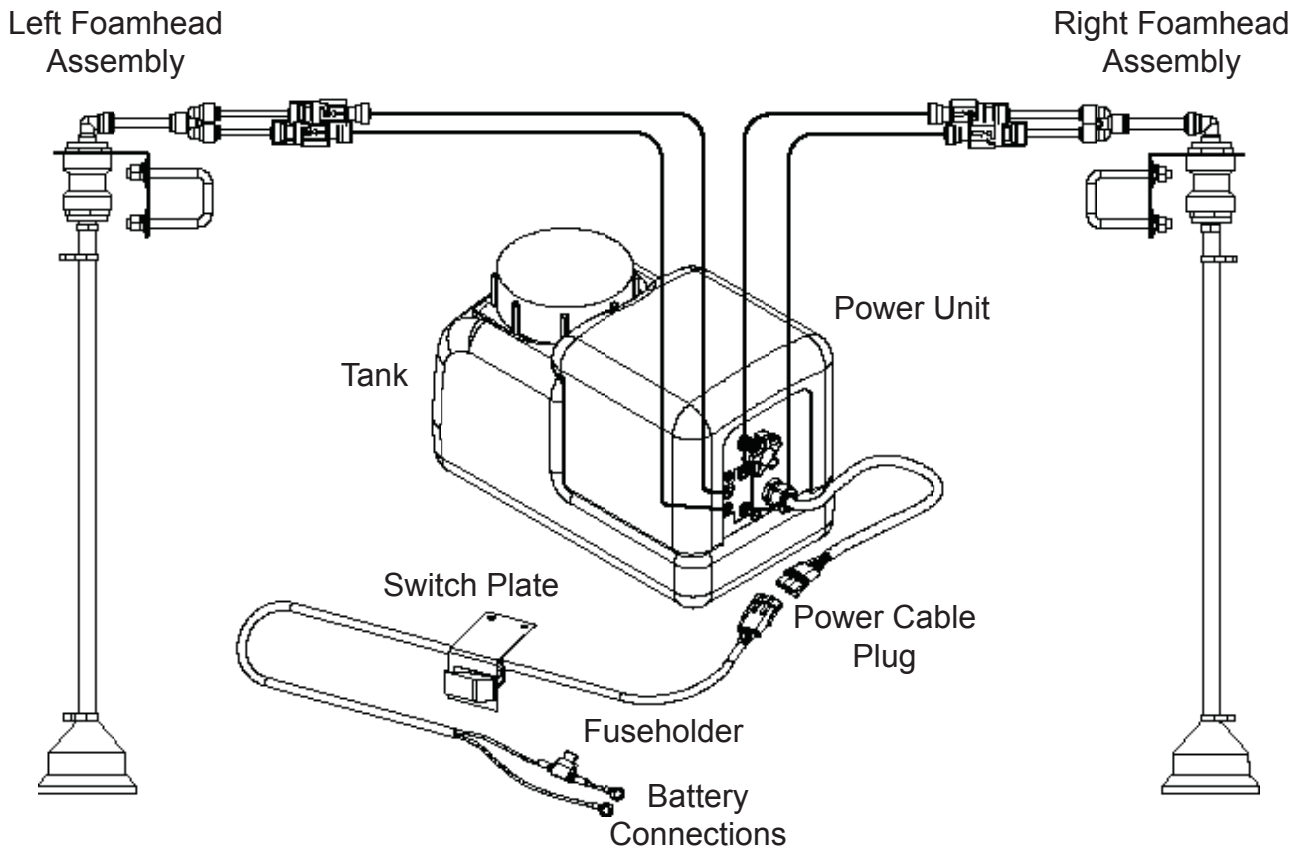

FIGURE 1 - MiniTrac Model MTD-2020 Foam Marker

### **TANK & POWER UNIT ASSEMBLY**

When considering a location for mounting the tank and power unit assembly, it will be important that the assembly is accessible for easy filling. The MiniTrac tank is designed to be mounted to a horizontal frame member or platform with two 1/4" molded brass inserts located on the bottom of the tank. The assembly should be attached to a platform or frame using 1/4" bolts of an appropriate length, with flat washers and lock washers.

It is best if the assembly is mounted in a contaminant free area to insure efficient, trouble-free operation.

## FOAMHEADS™

Foamheads are mounted at the end of the spray boom. If mounting a single-drop unit, mount the foamhead in a convenient location as needed. Ideally, the foamheads should be mounted one half the distance of your nozzle spacing beyond the last spray nozzle.

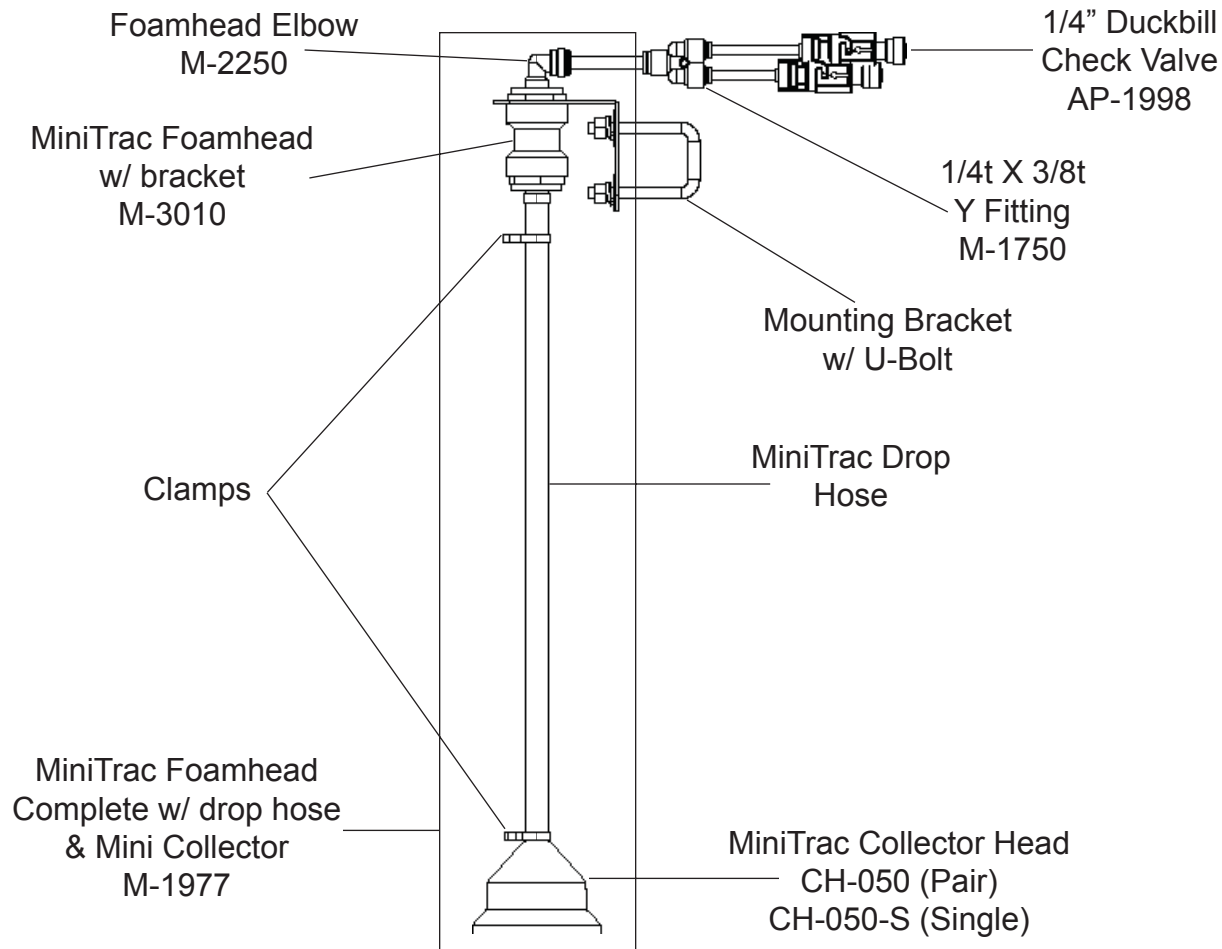

FIGURE 2 - MiniTrac Foamhead and Boom End Assembly

## FOAMHEAD TUBING

The MiniTrac 2020 and 2040 each come with 55 feet of 1/4" liquid tubing and 55 feet of 3/8" air tubing. MiniTrac 2020SD and 2040SD each come with 10 feet of 1/4" liquid tubing and 10 feet of 3/8" air tubing.

Route the 1/4" liquid and 3/8" air poly tubing lines from each foamhead assembly to the power unit. See Figure 3 for dual drop units and use the same procedure for single drop units with one set of tubing. Beginning at the end of your boom, attach the tubing using nylon cable ties, provided, to secure the tubing at 3 to 6 foot intervals. These ties assure a positive clamping without damaging the tubing. Be sure to leave enough slack at the hinge to fold and extend the spray boom. Repeat this procedure for the other side of your boom on dual drop units.

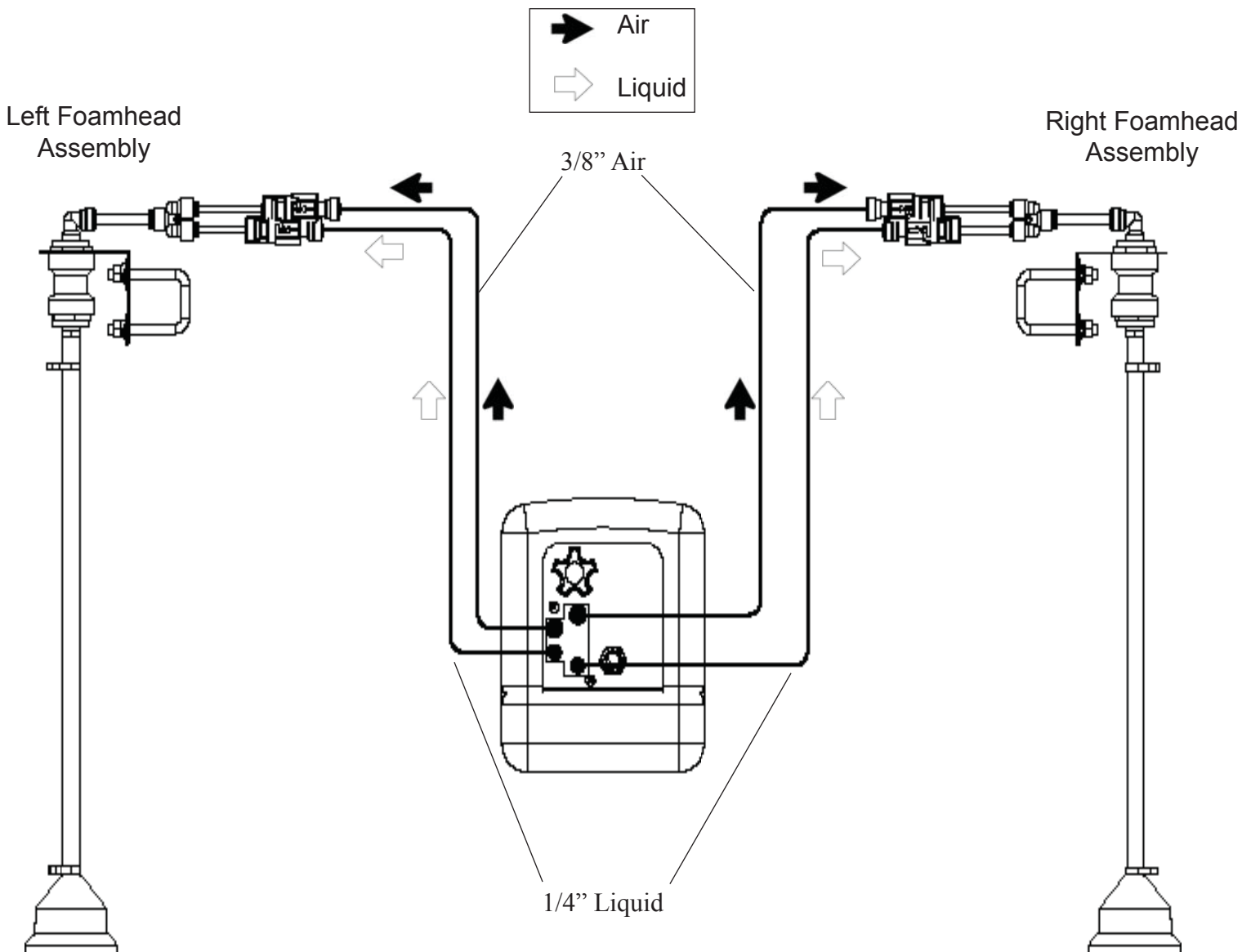

FIGURE 3 - MiniTrac Liquid and Air Flow

The MiniTrac 2020SD and 2040SD models will only have one air and liquid fitting. Connect the single air and liquid lines as shown above in the dual drop model. All MiniTrac foam markers are labeled to show where the air and liquid fittings connect to the power unit.

## SWITCH PLATE

Mount the switch plate in a location convenient to the operator. MiniTrac foam markers are equipped with an electrical plug assembly. This plug assembly allows for easy separation of the switch plate from the power unit. After the switch plate and power unit are installed, connect the plug assembly.

## WIRING



### Caution

- This machine is designed to operate off of a 12 volt DC power supply only.
- Do not operate this machine without covers in place.
- Never operate this machine with a damaged electrical cable.
- Only qualified personnel should perform repair service.
- Do not remove covers or attempt repairs while connected to electrical source.
- Never attempt to replace electrical wires and cables with smaller gauge or inferior products.
- Do not operate machine without the appropriate fuse.
- Do not attempt to bypass fuse.
- Never replace fuse with a higher amperage fuse.
- Inspect all components for damage after any electrical problem.
- Never operate this machine in or near explosive atmosphere or where aerosol products are used.

To prevent accidental grounding of circuit, do not connect the two-wire battery cable until all other connections have been made and checked for accuracy. If a greater length of wiring cable is needed, extension cables are available. When adding wire, be sure to use wire of the same or larger gauge. Using smaller wire can cause poor performance, blown fuses, and rapid compressor motor failure.

Route the two-wire battery cable from the switch plate to the battery. Be sure it is out of the way and secure it using plastic coated clamps to prevent damage from rubbing off insulation by sharp edges. The white wire of the battery cable should be attached directly to the positive (+) post of the battery by use of the ring mounting terminal. The black wire of the battery cable should be attached directly to the negative (-) mounting post. Check all connections for accuracy before completing battery connections.

**NOTE:** MiniTrac foam markers normally draw 4-6 amperes.

When connecting to an electrical system with two 6 volt batteries wired in series, be certain to connect the battery terminals so that a full 12 volts is supplied. If connected to 6 volts, the compressor will run slowly and the foam switching valves will not operate correctly.

Optional 3-wire Extension  
 w/ Male & Female Plugs  
 10 feet - M-1748  
 15 feet - M-1749

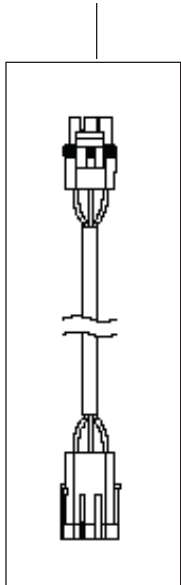

3-wire Cable w/ Male  
 Plug (18 ga.) 2'  
 M-1674

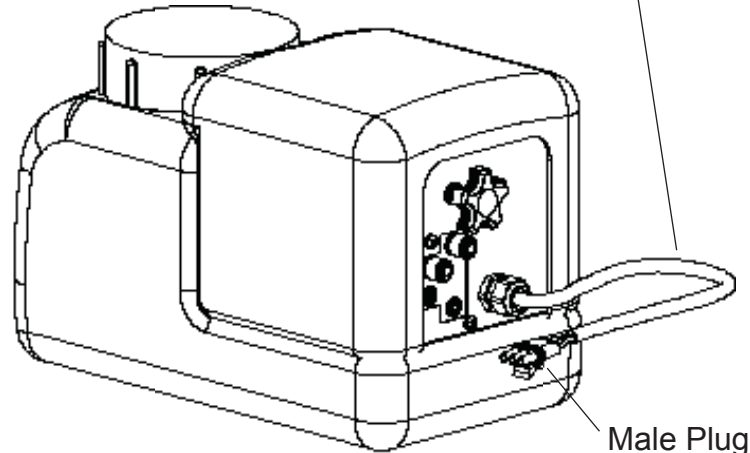

Male Plug  
 M-0387

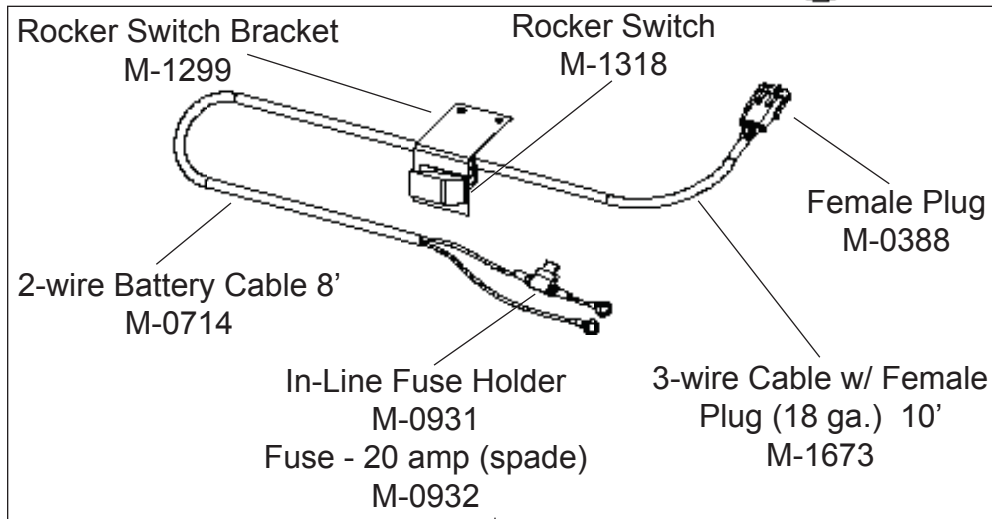

Switch and 2 Cable Assembly  
 M-1632

FIGURE 4 - MiniTrac Wire Harness Connections

Optional 2-wire Extension  
w/ Male & Female Plugs  
10 feet - M-1768  
15 feet - M-1824

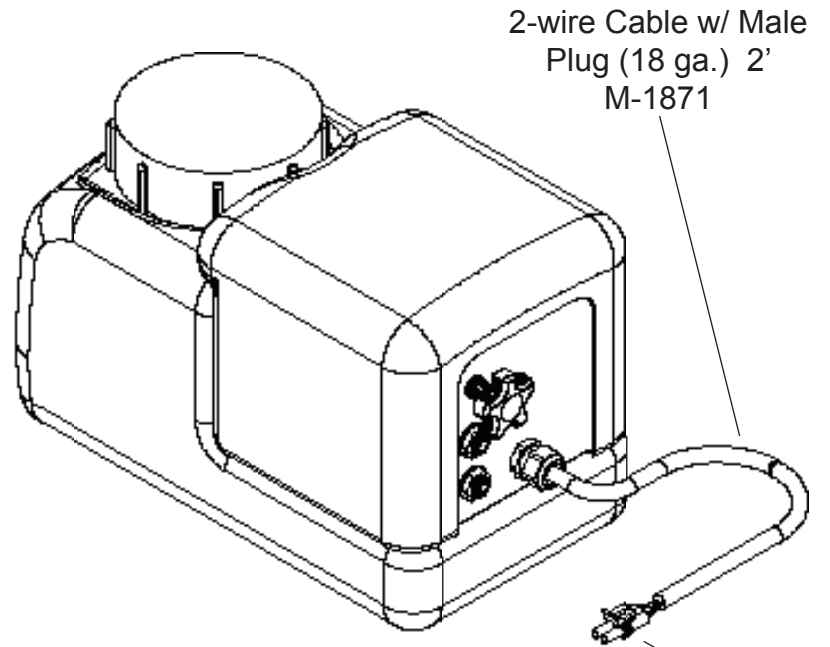
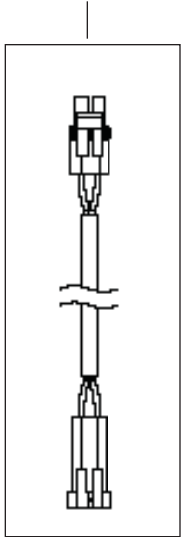

2-wire Cable w/ Male  
Plug (18 ga.) 2'  
M-1871

Male Plug  
M-1874

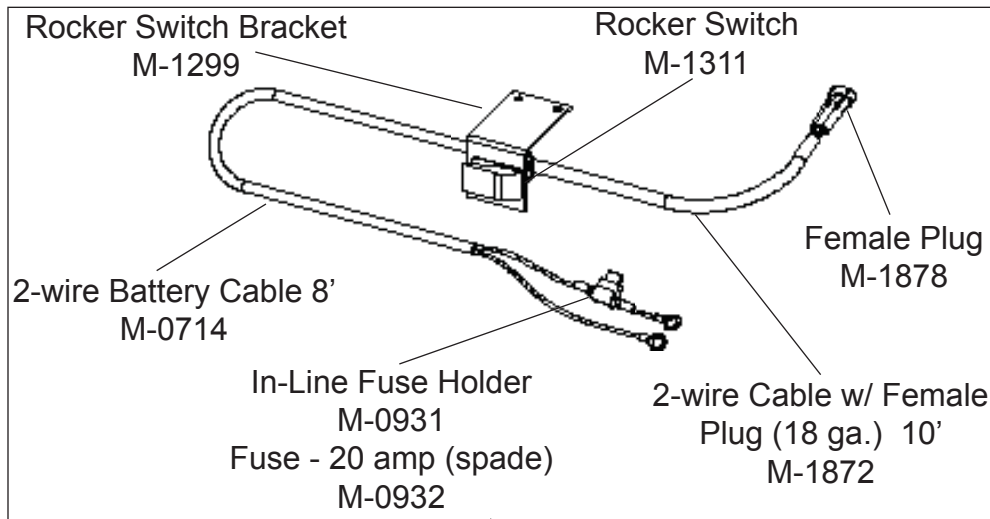

Rocker Switch Bracket  
M-1299

Rocker Switch  
M-1311

2-wire Battery Cable 8'  
M-0714

Female Plug  
M-1878

In-Line Fuse Holder  
M-0931  
Fuse - 20 amp (spade)  
M-0932

2-wire Cable w/ Female  
Plug (18 ga.) 10'  
M-1872

Single Drop Switch and 2 Cable Assembly  
M-1873

FIGURE 5 - MiniTrac Single Drop Wire Harness Connections

## OPERATION



### Caution

- Do not attempt to operate machine without covers in place.
- Never operate machine while unattended.
- Inspect machine for damage after use.
- Close supervision is necessary when this product is operated near children or invalids.
- Never allow children to operate this machine.
- Wear safety goggles and all proper clothing when operating, servicing or refilling this machine.
- Chemical mist or liquid can cause permanent eye, skin or lung damage or death.
- Always read and follow manufacturer recommendations when handling any chemical.
- Never operate this product in or near explosive atmospheres or where aerosol products are being used.
- Do not use air compressor to pump anything other than atmospheric air.
- Do not pump combustible liquids or vapors with this product or use in or near an area where flammable, explosive liquids, or vapors may exist.
- Do not use this product near flames.

## **COMPRESSOR CHECK**

After checking all wiring for accuracy, turn switch box to the “on” position and check that air is flowing out of the compressor.

## **MIXING FOAM**

Foam mixing takes some experience. Different water sources may require different amounts of concentrate to obtain the desired foam density. Water hardness, pH, and impurities will all affect the rate of concentrate required for a consistent, long-lasting foam.

Different conditions may require different mixing ratios to produce desirable results. It is worthwhile to determine the proper foam/water mixing ratios for your water source with the initial filling. Doing so will save time in the future and aid in consistent foam quality.

If hard water is a problem, commercial softening agents are available. You can make your own softening agent by dissolving a commercial water softening powder (available in most grocery stores) in hot water and adding a portion of this mixture to your tank each time you fill. Experimentation will reveal the correct amount to use. A good starting point is 1 1/2 ounces per gallon of water.

Mix ratios for foam concentrates advertised as 80:1 or 160:1 must be adjusted for use with your water, such ratios are only a guideline.

Heat, humidity, wind and crop cover will also affect the life of foam. Using a good quality marking agent, such as GOODMARK, may be very important.

**GOODMARK:** Premium life, "hot weather" foam concentrate, up to one hour life in cooler weather, 20-40 minutes in hot weather, good hard water tolerance.

## FILLING THE TANK



### Caution

- Wear safety goggles and all proper clothing when operating, servicing or refilling this machine.
- Always read and follow manufacturers recommendations when handling any chemical.
- Do not pump combustible liquids or vapors with this product.

1. **BE SURE POWER UNIT IS TURNED OFF.** Remove the cap from the top of the tank.
2. Starting with a small amount of water (2 gal), mix the foam concentrate according to the label directions. If considerably more concentrate is needed above the manufacturer's suggested ratio (usually 2-5 ounces per gallon) to produce good foam, use of a softener or soft water may be required. If the foam is too stiff (dry), it may surge out at irregular intervals. Under this condition, water should be added until the foam becomes more wet.
3. To ensure proper mixing of foam concentrate and water, you may find it necessary to partially fill the tank, add the foam concentrate, then completely fill the tank.
4. Replace cap at the top of the tank.

## FLOW CONTROL VALVE / TUBING CONNECTIONS

The flow control valve regulates the amount of foam solution flowing to the foamheads. To increase liquid flow, turn the adjusting knob counter-clockwise. This valve has been factory preset at ½ turn open. This setting provides for a moderate foam output.

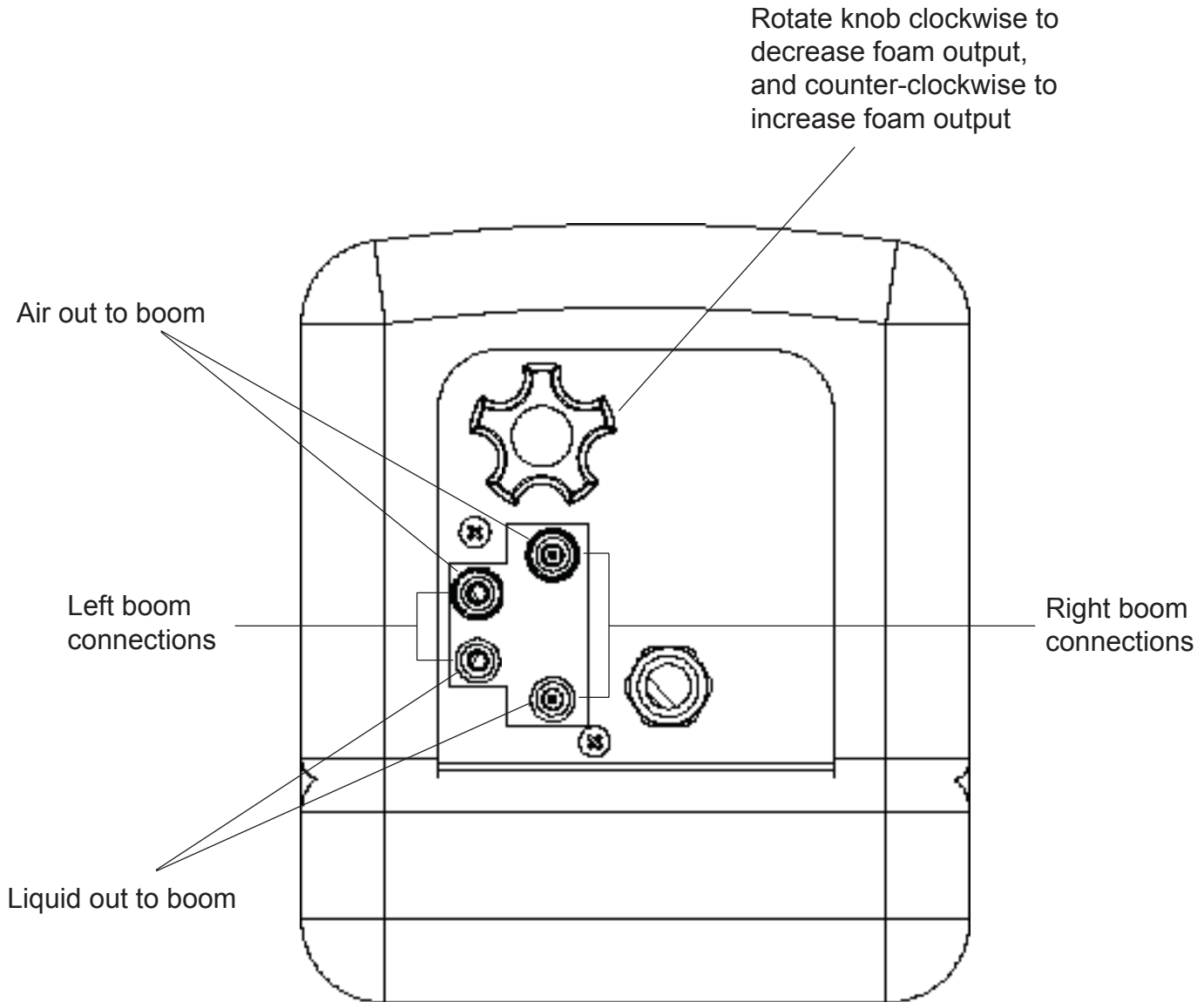

FIGURE 6 - MiniTrac Flow Control Valve Adjustment and Air/Liquid Connections

Rotate knob clockwise to decrease foam output, and counter-clockwise to increase foam output

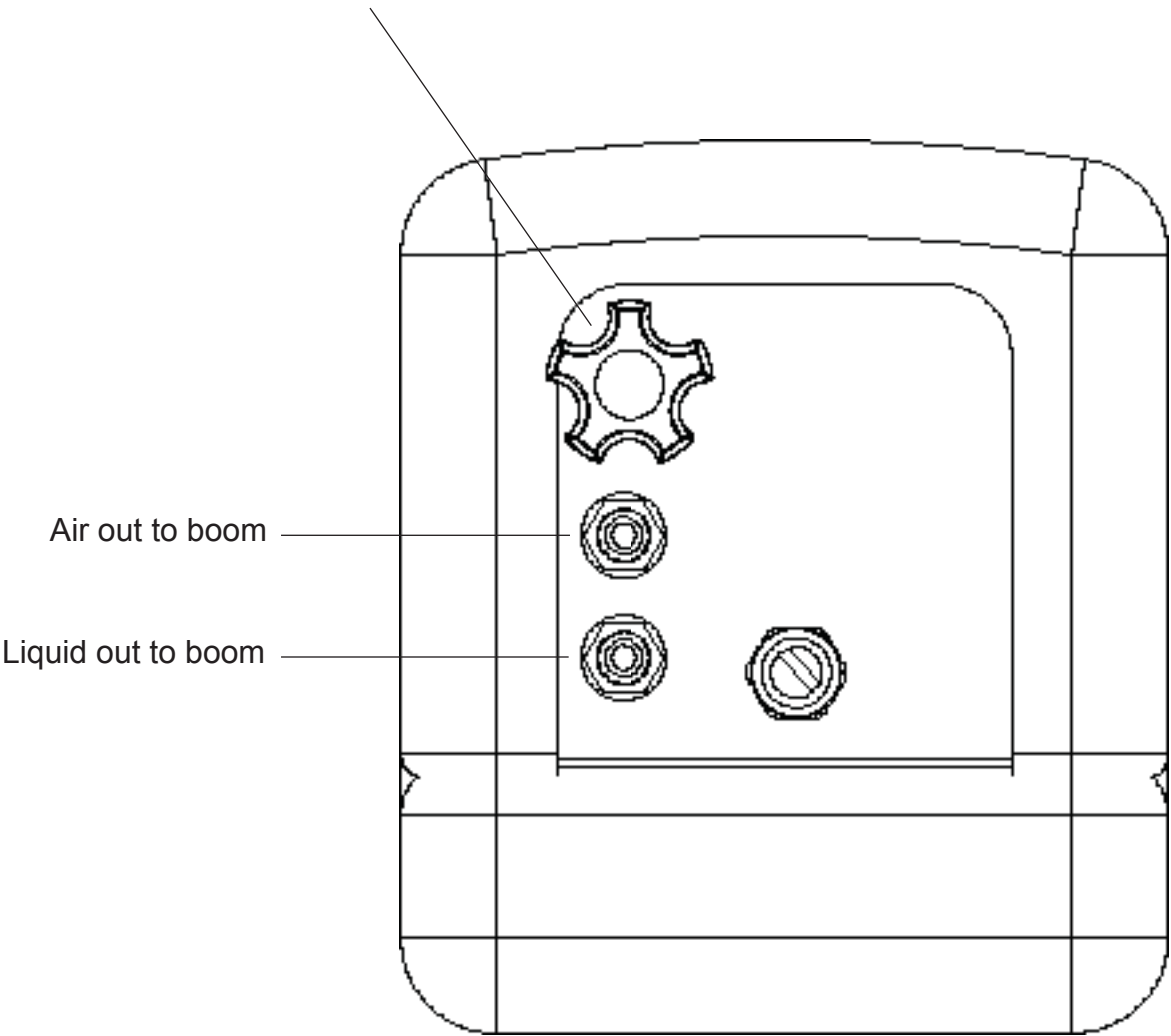

FIGURE 7 - MiniTrac Single Drop Flow Control Valve Adjustment and Air/Liquid Connections

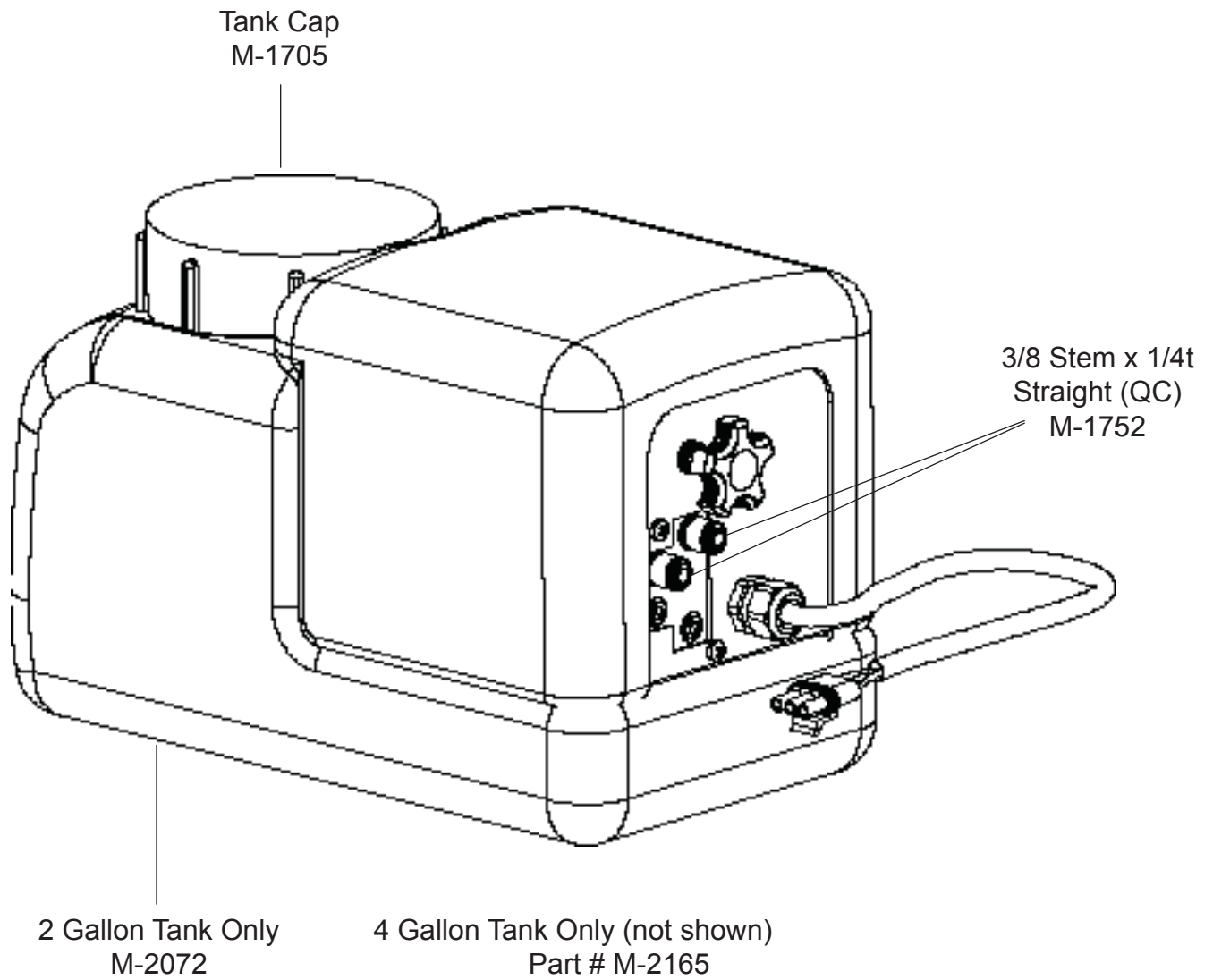

FIGURE 8 - MiniTrac Power Unit External Components

## MAINTENANCE



### Caution

- All electrical components generate heat. To avoid serious burns, never touch internal components immediately after use.
- The air compressor in this unit may be thermally protected and may automatically restart when the protector resets. Always disconnect power source before servicing.
- Wear goggles and all protective clothing when operating, servicing or refilling this machine. Always read and follow manufacturer recommendations when handling any chemical.
- Do not remove covers or attempt repairs while connected to electrical source.
- Disassembly or attempted repairs, if accomplished incorrectly, can create hazards. Only qualified personnel should perform repair service.

## FOAMHEADS AND SCREEN/STRAINER

The foamheads have been designed so that the elements inside may be cleaned as necessary. Remove the foamheads from the boom and rinse thoroughly with hot water.

The screen/strainer located in the tank should be checked occasionally to insure sufficient liquid flow to the foamhead assemblies.

## TANK AND HOSES

At the end of the season flush the tank with warm water. Check the airlines and liquid lines for holes and replace as required. Be sure to flush, then drain, all liquid from the system prior to storage in freezing temperatures.

### IMPORTANT

The liquid lines and tank must be drained completely prior to storage. If liquid in this system is allowed to freeze, several components may be damaged.

## WINTERIZATION

Follow the procedures below to prevent component damage.

1. Remove the in-line filter at the bottom of the tank and completely flush the tank with warm water.
2. Replace in-line filter. Turn on machine and allow to operate until no foam is generated.
3. Add anti-freezing solution such as windshield washer solvent to tank.
4. Turn on machine until anti-freezing solution reaches the foamheads.
5. Check the airlines and liquid lines for holes and replace as required. **Be sure to flush, then drain, all liquid from the system prior to storage in freezing temperatures.**

## **TROUBLE-SHOOTING**

If you do not get foam:

1. Be sure the airline and liquid lines do not have a hole in them or are not pinched, and remove air and liquid tubing at each foamhead and check for flow.
2. Be sure you have enough foam concentrate in the tank. Very hard water may require a great amount of concentrate to produce good foam. Not having enough foam concentrate in the tank may make good foam, but may not make enough foam. Be sure to use a high quality concentrate such as GOODMARK.
3. Check and clean the screen-strainer located in the tank.
4. Be sure the flow control valve is open.
5. If the foam mixture in the tank is several days old, it is possible that the solution is no longer able to foam, or produces little foam. Drain tank, rinse, and start with a fresh solution.
6. Check battery connections to be certain the positive and negative terminals are not reversed.

<b>Problem</b>	<b>Solution</b>
Not enough foam	<ul style="list-style-type: none"> <li>• Add more foam concentrate to tank</li> <li>• Check for holes in airline</li> <li>• Check for pinched air or liquid lines</li> <li>• Clean screen-strainer/foamhead</li> <li>• Adjust liquid flow control valve</li> </ul>
Wet foam	<ul style="list-style-type: none"> <li>• Add more foam concentrate to tank</li> <li>• Clean screen-strainer/foamhead</li> <li>• Reduce liquid flow</li> </ul>
Foam is surging	<ul style="list-style-type: none"> <li>• Use less concentrate</li> </ul>
Foam does not last on the ground	<ul style="list-style-type: none"> <li>• Add more foam concentrate to tank</li> <li>• Use a high quality foam concentrate like GOODMARK</li> <li>• Use collector heads</li> </ul>
Blowing foam in windy weather	<ul style="list-style-type: none"> <li>• Use less concentrate to make wetter foam</li> <li>• Add more water to foam solution</li> <li>• Increase liquid flow</li> </ul>

# APPENDIX 1

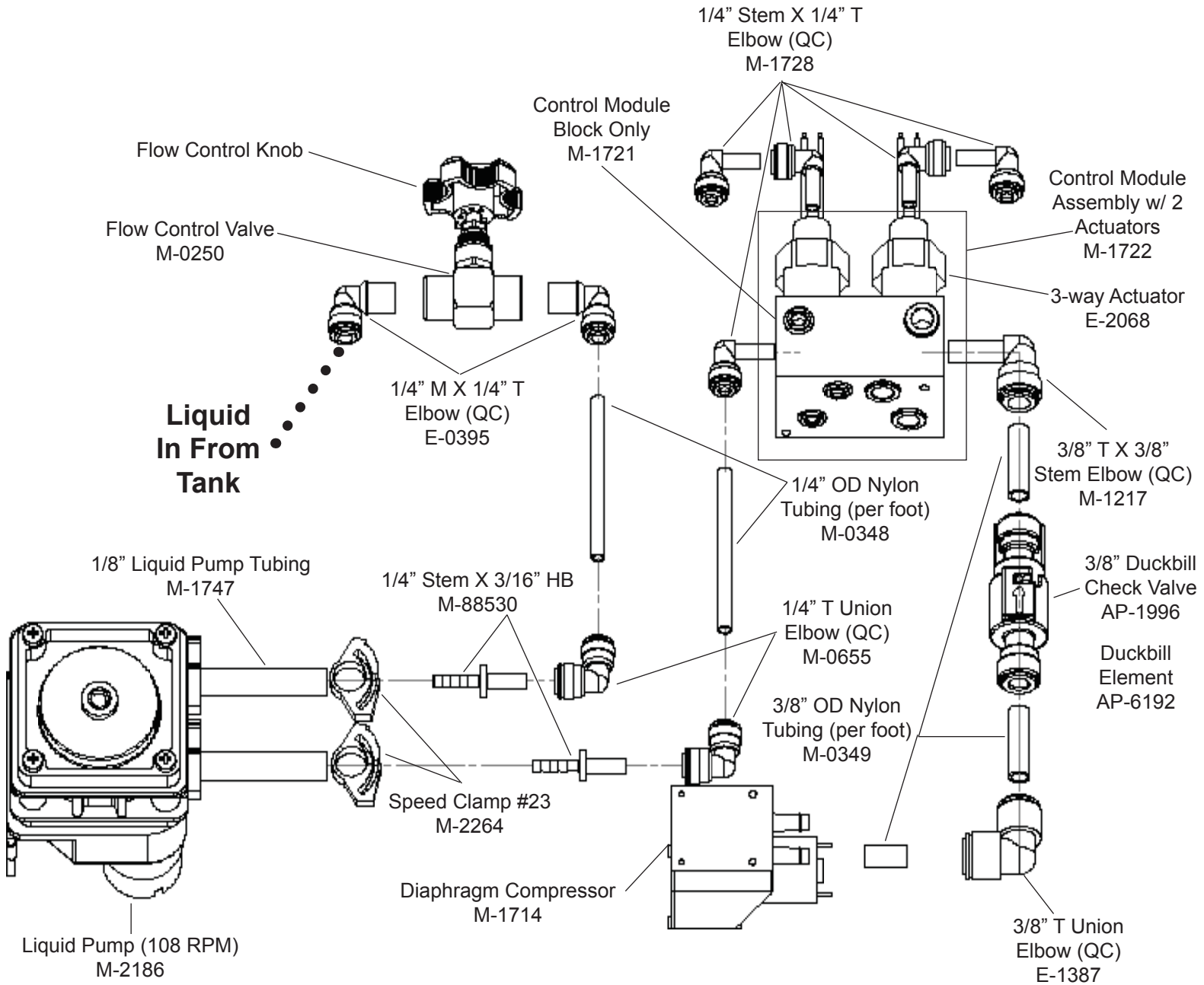

FIGURE 9 - MiniTrac Power Unit Internal Components

## APPENDIX 2

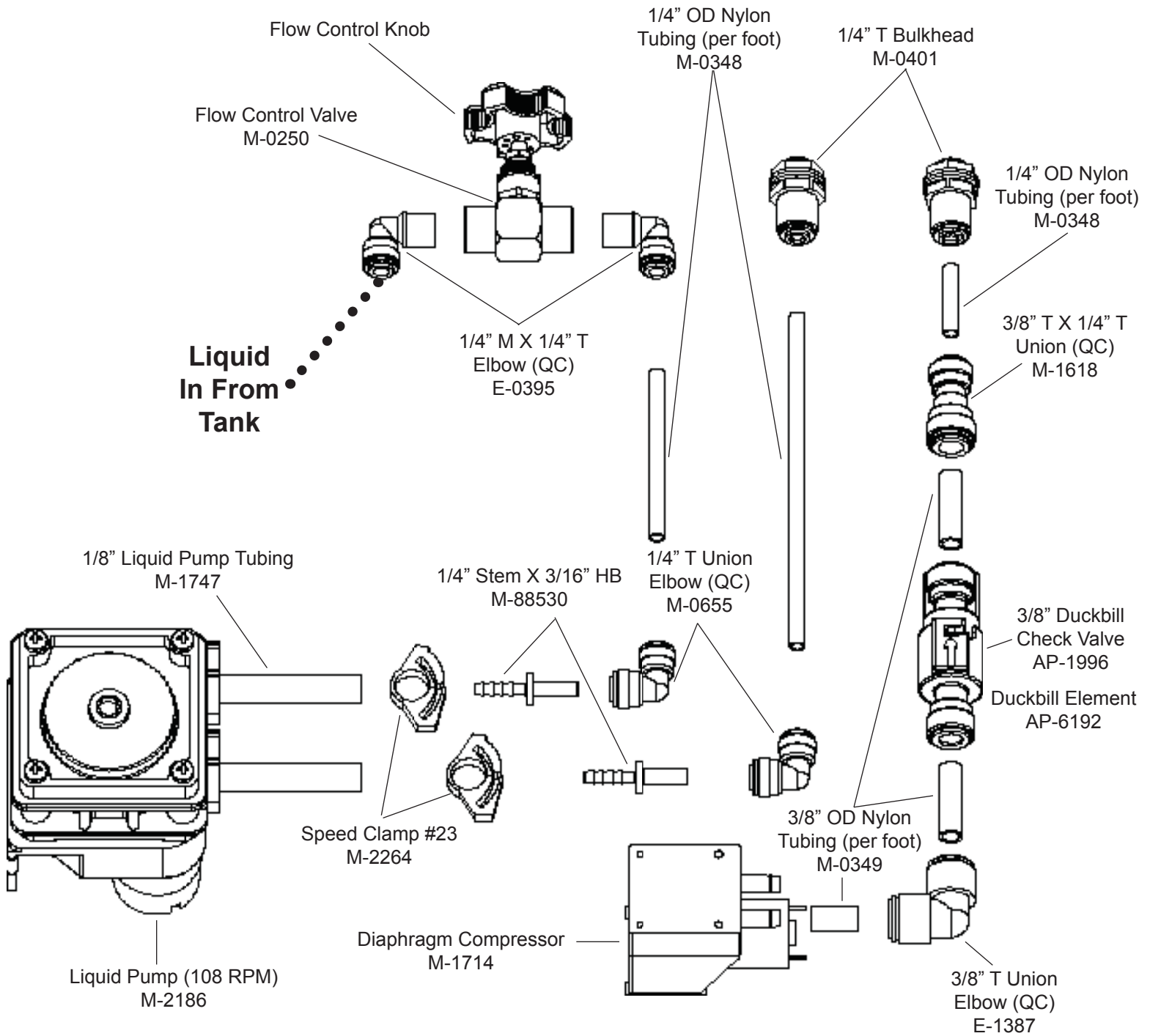

FIGURE 10 - MiniTrac Single Drop Power Unit Internal Components



# APPENDIX 5

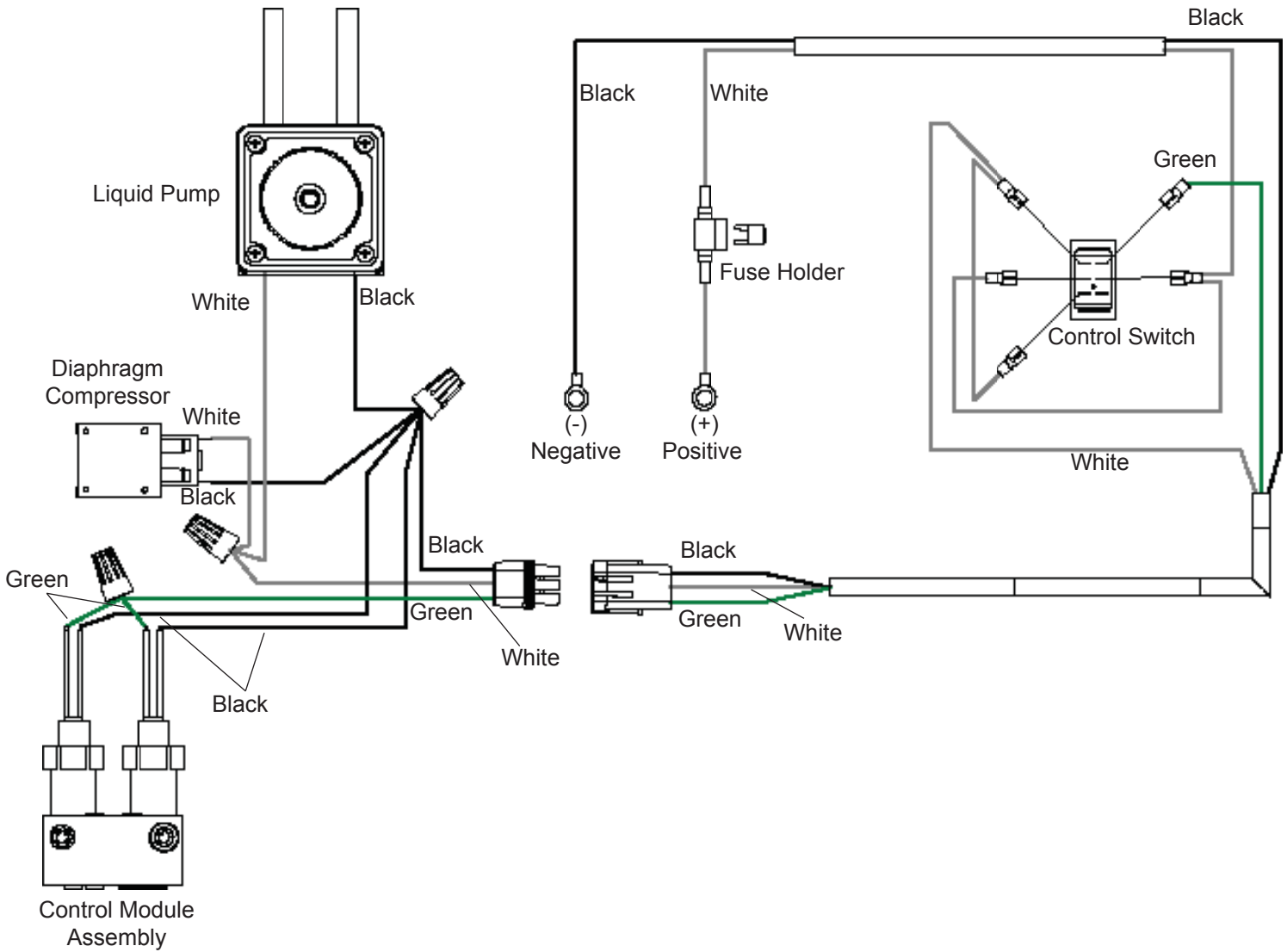

FIGURE 13 - MiniTrac Wiring Diagram

## **WARRANTY INFORMATION**

### **Limited Warranty**

Richway Industries, Ltd., foam marking systems and components are warranted against defects in materials and workmanship for a period of 1 year from date of shipment.

During this warranty period, Richway will repair or replace at no charge, those parts or components which upon receipt by Richway, following warranty analysis, prove to be defective.

This warranty does not apply to parts or products not manufactured by Richway Industries, Ltd., including but not limited to solenoid valves, diaphragm compressors, etc., the warranty of such items being limited to the actual warranty extended to Richway Industries, Ltd., by its supplier.

Further, this warranty does not cover part or component failures or damage due to misapplication, misuse, abuse, breakage, or improper installation, storage or handling, abnormal conditions of temperature, water, dirt, corrosive or other contaminants.

Products covered by this warranty must be used in compliance with all federal, state, and local regulations.

### **Disclaimer of Other Warranties**

The foregoing limited warranty is in lieu of all other warranties, expressed or implied, including merchantability or fitness for a particular purpose. In no event shall Richway Industries, Ltd., be liable for indirect, consequential or special damages of any nature, whatsoever.

## **COMPANY INFORMATION**

Richway Industries, Ltd.  
504 North Maple P.O. Box 508  
Janesville, Iowa 50647 (USA)  
Toll free 800-553-2404 Fax 319-987-2251  
info@richway.com  
www.richway.com